

**N-RACK**

embellishing your enclosures...

**Industrial Hardware** | embellishing your enclosures...**Model: MS 460-1-1E**

RL

IP54

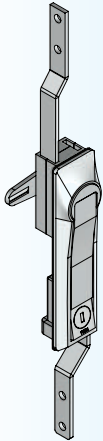
**Photo View****3D Rendered View**

- ▶ MATERIAL: ZINC DIE-CASTING BODY, ZINC PLATING FIXING PARTS, SAND BRIGHT CHROME PLATING RACK
- ▶ FINISH: GREY CHROME PLATING
- ▶ PANEL THICKNESS: 1-2.5MM
- ▶ REMARK: CAM CUTOUT 8X8

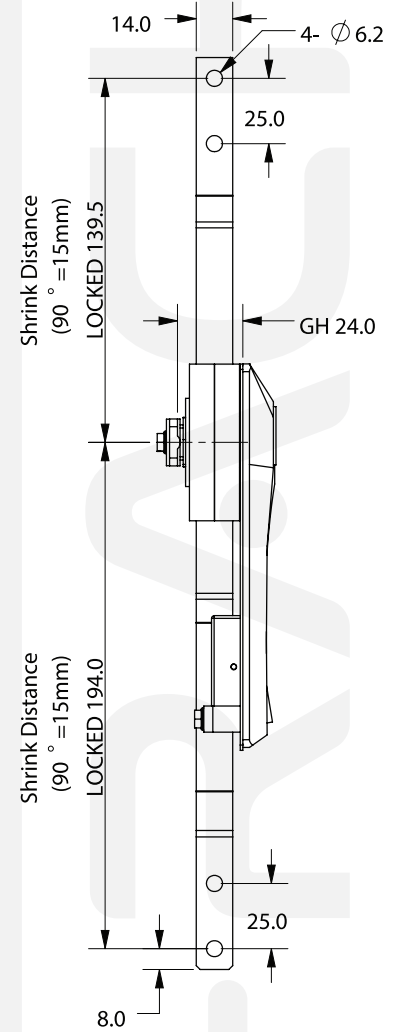
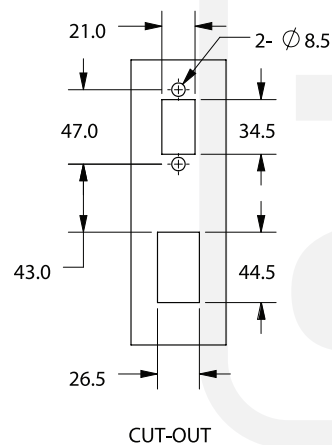
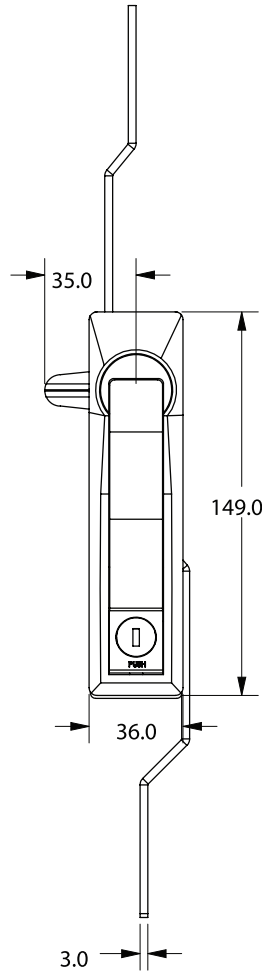

embellishing your enclosures...